

# HVF & HVG Type Vacuum Circuit Breaker

[ IEC 62271-100 ]

V  
C  
B

Vacuum  
Circuit  
Breaker



HVF & HVG Type

# Vacuum Circuit Breaker

VCB

Vacuum Circuit Breaker

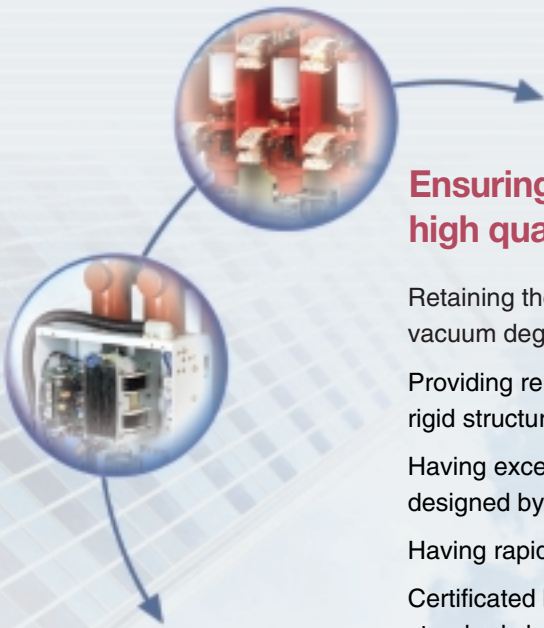

## Ensuring excellent switching capability and high quality with various advantages

Retaining the high dielectric strength with the interrupter of the high vacuum degree of  $10^{-7}$ mbar.

Providing reliable mechanical performance and long-life expectancy with rigid structure of motor-spring energy stored mechanism.

Having excellent breaking capability with the special contact material designed by the advanced vacuum technology.

Having rapid breaking time of 3 cycle.

Certificated by New IEC publication 62271-100 and other related standards by HYUNDAI in ISO 9001 certified facilities.

Vacuum Circuit Breaker

## C O N T E N T S

Description and Ratings .....	4	Control & Auxiliary Circuits .....	14
HVF Type .....	4	Standard Accessories .....	15
HVG Type .....	8	Optional Accessories .....	15
Type of Mounting .....	10	Control Circuit .....	16
Technical Data .....	11	Layout .....	18
Arc Quenching System .....	12	Ordering Form .....	27
Service Life .....	13		

## HVF

### Rigid structure to prove high reliability and long-life expectancy

- Wide 600 / 800 mm switchgear available with small size & light weight
- Mechanical endurance of 30,000 operations
- (IEC)
 

7.2~17.5 kV	25~40 kA	630~3150 A
24/25.8 kV	12.5~25 kA	630~2000 A
36 kV	25 kA	1250~2500 A
- (ANSI)
 

4.76 kV	50 kA	1200 A
15 kV	40 kA	1200~2000 A
38 kV	31.5~40 kA	1200~3000 A

## HVG

### Compact structure to minimize the switchgear size

- Wide 600 mm switchgear available with small size & light weight
- Mechanical endurance of 20,000 operations
- 7.2 kV, 8~25 kA, 400~1250 A

Vacuum Circuit Breaker

# B



HVG VCB

HVF VCB

## Description and Ratings HVF Type

With rigid structure and minimized moving parts, HVF breaker operation mechanism features reduced maintenance requirements providing high reliability and long-life expectancy.

The breakers are more compactly designed in size with high performance vacuum interrupters, which are made with the special contact material and the advanced vacuum technology.

This series are certificated by New IEC publication 62271-100, ANSI C 37 and other domestic standards.

### Operating Mechanism

HVF circuit breakers have motor-spring energy stored mechanisms of the rigid structure. It consists of the charging mechanism, the closing spring, the trip spring, the motor, solenoids, auxiliary switches, spring charged and on/off indicators as shown in Fig.1.

Depending on the intended protection functions, the operating mechanism can be supplemented by 2nd shunt release, under voltage release, lockout relay, cut-out switch, limit switch, electrical local closing and so on.

The released closing spring is automatically recharged by the charging motor, and capable of the operating sequences " open-close-open " which is required when unsuccessful auto-reclosing operation is attempted.

### Pole Part

The pole parts are placed on the rear side of the operating mechanism. The internal side of the pole parts are well enclosed by the tubular type insulation frame as shown in Fig.2.

This prevents dust on the internal insulation material which is highly resistant to tracking.

The vacuum interrupters are mounted rigidly in the insulation frame, so withstand forces arising from switching operation and contact pressure.

In the closed state, the necessary contact pressure is established by the contact pressure spring and the atmospheric pressure. The contact pressure spring automatically compensates the arc erosion which is very small.

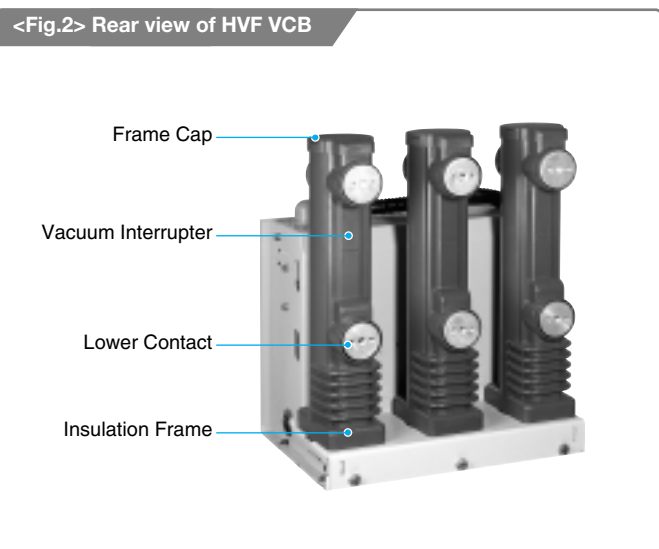
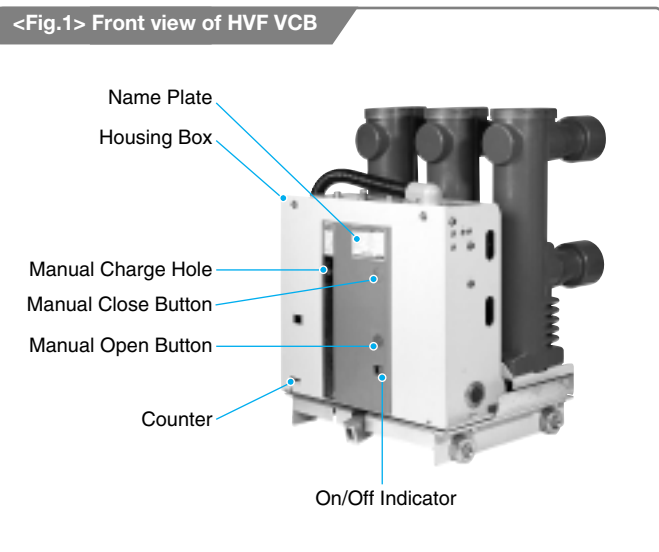

## Type & Ratings

Type No. <sup>1)</sup>	HVF114 呷	HVF115 呷	HVF116 呷	HVF2141 呷	HVF215 呷	HVF216 呷
Application Standard	IEC 62271-100					
Rated Voltage (kV)	7.2			12		
Frequency (Hz)	50 / 60					
Rated Current (A)	630	1250	1250	630	1250	1250
	1250	2000	2000	1250	2000	2000
			2500			2500
			3150			3150
Rated Short-circuit Breaking Current (kA)	25	31.5	40	25	31.5	40
Rated Short-circuit Making Current (kA)	65	82	104	65	82	104
Short-time Withstand Current for 3 sec (kA)	25	31.5	40	65	82	104
Power-frequency Withstand Voltage (kV, 1 mim)	20			28		
Impulse Withstand Voltage (kV, 1.2 × 50 μs)	60			75		
Operating Duty	O - 0.3 sec - CO - 3 min - CO / CO - 15 sec - CO					
Closing Time (ms)	52 (at DC 110 V)					
Opening Time (ms)	32 (at DC 110 V)					
Breaking Time (cycles)	3					
Closing Operation	System	Motor Spring Stored Energy				
	Supply Voltage (V)	DC 48, 60, 110, 125 / AC 110, 125, 220				
	Current (A)	Refer to Table 3 (see page 14)				
Closing & Tripping Control	Tripping System	Shunt Trip				
	Supply Voltage (V)	DC 48, 60, 110, 125, 220 / AC 110, 125, 220				
	Current (A)	Refer to Table 3 (see page 14)				
Operating Life (times)	Mechanical Operation	30,000				
	Electrical Operation	Refer to Table 2 (see page 13)				
Auxiliary Contacts	4NO+4NC (Max. 10NO+10NC+1W)					
Weight (kg) (Main-body)	110	110	115	110	110	115
	110	130	130	110	130	130
			145			145
			145			145

<sup>1)</sup> Type number in the square " 呷 " Shall be listed as shown in the line for the rated current.

## Description and Ratings HVF Type

### Type & Ratings

Type No. <sup>1)</sup>	HVF314 ㉑	HVF315 ㉑	HVF316 ㉑	HVF611 ㉑	HVF614 ㉑	HVF714 ㉑
Application Standard	IEC 62271-100					
Rated Voltage (kV)	17.5			24 / 25.8		36
Frequency (Hz)	50 / 60					
Rated Current (A)	630	1250	1250	630	630	1250
	1250	2000	2000	1250	1250	2000
			2500		2000	2500
			3150			
Rated Short-circuit Breaking Current (kA)	25	31.5	40	12.5	25	25
Rated Short-circuit Making Current (kA)	65	82	104	32.5	65	65
Short-time Withstand Current for 3 sec (kA)	25	31.5	40	12.5	25	25
Power-frequency Withstand Voltage (kV, 1 mim)	38			50		70
Impulse Withstand Voltage (kV, 1.2 × 50 μs)	95			125		170
Operating Duty	O - 0.3 sec - CO - 3 min - CO / CO - 15 sec - CO					
Closing Time (ms)	52			68		75
Opening Time (ms)	32					45
Breaking Time (cycles)	3					5
Closing Operation	System	Motor Spring Stored Energy				
	Supply Voltage (V)	DC 48, 60, 110, 125 / AC 110, 125, 220				
	Current (A)	Refer to Table 3 (see page 14)				
Closing & Tripping Control	Tripping System	Shunt Trip				
	Supply Voltage (V)	DC 48, 60, 110, 125, 220 / AC 110, 125, 220				
	Current (A)	Refer to Table 3 (see page 14)				
Operating Life (times)	Mechanical Operation	30,000				
	Electrical Operation	Refer to Table 2 (see page 13)				
Auxiliary Contacts	4NO+4NC (Max. 10NO+10NC+1W)					
Weight (kg) (Main-body)	120	120	130	130	130	280
	120	135	145	130	130	300
			160		145	340
			160			

1) Type number in the square " ㉑ ". Shall be listed as shown in the line for the rated current.

### Type & Ratings

Type No. <sup>1)</sup>	HVF137 ㉑	HVF336 ㉑	HVF705 ㉑	HVF706 ㉑	HVF105 ㉑	HVF204 ㉑
Application Standard	ANSI C 37.09				IEC 60056 (KR, GL)	IEC 60056 (KR, GL)
Rated Voltage (kV)	4.76	15	38		7.2	12
Frequency (Hz)	50 / 60					
Rated Current (A)	1200	1200	1200	1200	630	630
		2000	2000	2000	1250	1250
			3000	3000	2000	2000
Rated Short-circuit Breaking Current (kA)	50	40	31.5	40	31.5	25
Rated Short-circuit Making Current (kA)	130	104	80	104	82	65
Short-time Withstand Current (kA)	50 (2 sec)	40 (2 sec)	31.5 (3 sec)	40 (3 sec)	31.5 (3 sec)	25 (3 sec)
Power-frequency Withstand Voltage (kV, 1 min)	19	36	80	80	20	28
Impulse Withstand Voltage (kV, 1.2 x 50 μs)	60	95	150	150	60	75
Operating Duty	O - 15 sec - CO - 3 min - CO	O - 0.3 sec - CO - 3 min - CO				
Closing Time (ms)	75	75	75	75	75	75
Opening Time (ms)	60	60	50	50	60	60
Breaking Time (cycles)	5					
Closing Operation	System	Motor Spring Stored Energy				
	Supply Voltage (V)	DC 24, 48, 60, 110, 125 / AC 110, 125, 220				
	Current (A)	Refer to Table 3 (see page 14)				
Closing & Tripping Control	Tripping System	Shunt Trip				
	Supply Voltage (V)	DC 24, 48, 60, 110, 125, 220 / AC 110, 125, 220				
	Current (A)	Refer to Table 3 (see page 14)				
Operating Life (times)	Mechanical Operation	30,000	20,000		30,000	
	Electrical Operation	Refer to Table 2 (see page 13)				
Auxiliary Contacts	4NO+4NC (Max. 10NO+10NC+1W)					
Weight (kg) (Main-body)	165	170	230	340	150	150
		190	250	365	160	160
			300	400		

1) Type number in the square " ㉑ " Shall be listed as shown in the line for the rated current.

## Description and Ratings HVG Type

HVG Vacuum circuit-breakers are very compact, so that it is possible to reduce the switchgear size and to minimize its insulation space.

This type has the compact structure, which can be easily maintained, so it requires minimized maintenance.

### Operating Mechanism

HVG vacuum circuit breakers have the simplified motor spring energy stored mechanism which consists of the closing spring, the motor, link mechanisms solenoids, auxiliary switches and indicators as shown in Fig.3.

The closing spring can be charged manually or electrically, and released mechanically with the manual closing push button or electrically through the remote electrical control.

The released closing spring is automatically recharged by the charging motor, and capable of the operating sequences " open-close-open " which is required when unsuccessful auto-reclosing operation is attempted.

### Pole Part

The pole parts are mounted on the rear side of the operating mechanism in the insulation frame.

The vacuum interrupter is mounted rigidly in the insulation frame, so that it withstands forces arising from switching operation and contact pressure.

The current conducting path consists of the plug-in contacts, terminals, the vacuum interrupter and the flexible terminal.

<Fig.3> Front view of HVG VCB

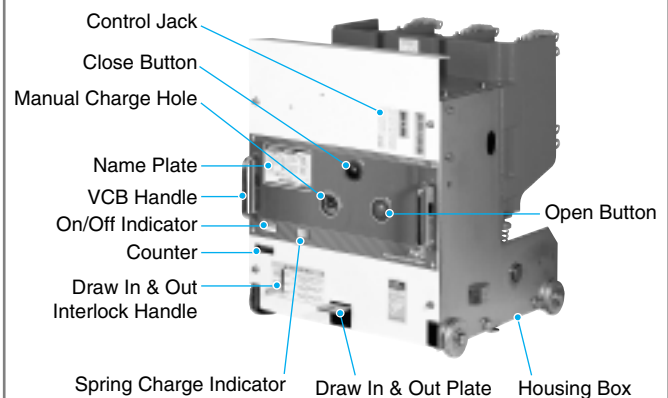

<Fig.4> Rear view of HVG VCB

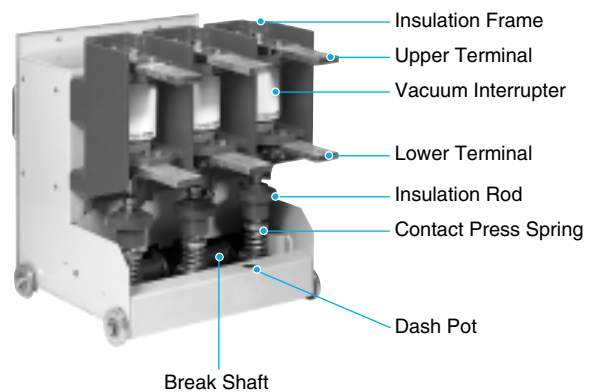



### Type & Ratings

Type No.	HVG1099	HVG1011	HVG1131	HVG1132	HVG1141	HVG1142	
Application Standard	IEC 62271-100						
Rated Voltage (kV)	7.2						
Frequency (Hz)	50 / 60						
Rated Current (A)	400	630	630	1250	630	1250	
Rated Short-circuit Breaking Current (kA)	8	12.5	20		25		
Rated Short-circuit Making Current (kA)	20	32.5	52		65		
Short-time Withstand Current for 1sec (kA)	8	12.5	20		25		
Power-frequency Withstand Voltage (kV, 1 min)	20						
Impulse Withstand Voltage (kV, 1.2 × 50 μs)	60						
Operating Duty	O - 0.3 sec - CO - 3 min - CO		O - 0.3 sec - CO - 3 min - CO / CO - 15 sec - CO				
Closing Time (ms)	32 (at DC 110 V)						
Opening Time (ms)	22 (at DC 110 V)						
Breaking Time (cycles)	3						
Closing Operation	System	Motor Spring Stored Energy					
	Supply Voltage (V)	DC 48, 60, 110, 125 / AC 110, 125, 220					
	Current (A)	Refer to Table 3 (see page 14)					
Closing & Tripping Control	Tripping System	Shunt Trip					
	Supply Voltage (V)	DC 48, 60, 110, 125, 220 / AC 110, 125, 220					
	Current (A)	Refer to Table 3 (see page 14)					
Operating Life (times)	Mechanical Operation	20,000					
	Electrical Operation	Refer to Table 2 (see page 13)					
Auxiliary Contacts	4NO+4NC (Max. 7NO+7NC)						
Weight (kg)	Fixed Type	52	63	65	65	65	65
	Draw-out Type	52	67	70	70	70	70

## Type of Mounting

As the standard version, the fixed type and three kinds of withdrawable type circuit breaker can be provided on request.

The draw-out type breakers consist of truck, mechanical interlock, control terminal, and various accessories.

<b>XA Type</b>	Fixed type VCB without cradle
<b>ES Cradle</b>	Draw-out type VCB with E type cradle (Without shutter)
<b>FS Cradle</b>	Draw-out type VCB with F type cradle (Nonmetallic partition with shutter)
<b>GS Cradle</b>	Draw-out type VCB with G type cradle (Metallic partition & bushing with shutter)

Besides the standard version of draw-out circuit breakers, specially designed breakers like those for are available on request, such as ANSI standards or retrofit.

<Fig.5> XA Type (HVF VCB)

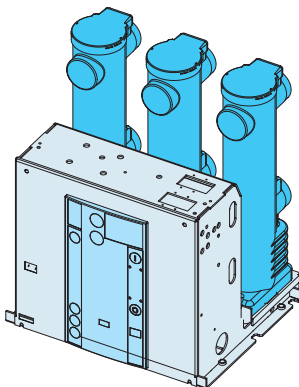

<Fig.6> ES Cradle (HVF VCB)

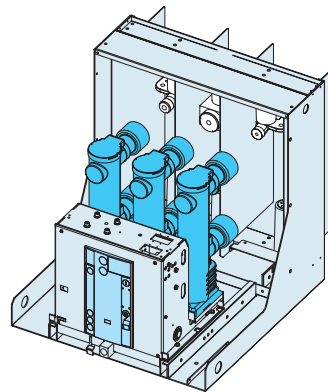

<Fig.7> FS Cradle (HVF VCB)

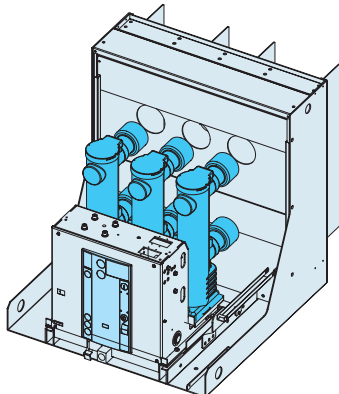

<Fig.8> GS Cradle (HVF VCB)

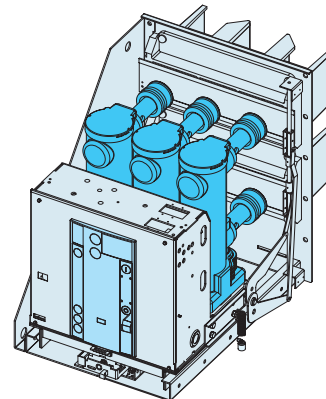

# Technical Data Application

## Applicable Standards

HYUNDAI vacuum circuit breakers meet IEC 62271-100, IEC 60056, and ANSI 37.09.

## Rapid Load Transfer & Operating Duty

With its consistent short closing and operating times, Hyundai vacuum circuit breakers are especially beneficial in load transfer from one circuit to another without interruption of service.

This high speed operation performs synchronizing of the systems to be paralleled at the instant of contact closure as well. According to the relevant standards and breaker types, tests were carried out for the following operating duties.

- CO - 15 sec - CO
  - O - 0.3 sec - CO - 3 min - CO
  - O - 15 sec - CO - 3 min - CO
- (O : Open, C : Close)

## Current Carrying Capacity

HYUNDAI vacuum circuit breakers may be operated at ambient temperatures between -25 and +40 . The rated normal currents determined according to IEC standards at an ambient temperature of 40 .

When the breakers are operated at different temperature, the correction on operating current must be considered. Fig.9 shows appropriate operating currents at different ambient temperature.

However, the diagram applies only to open type switchgear, so metal enclosed switchgear load currents shall be reduced accordingly.

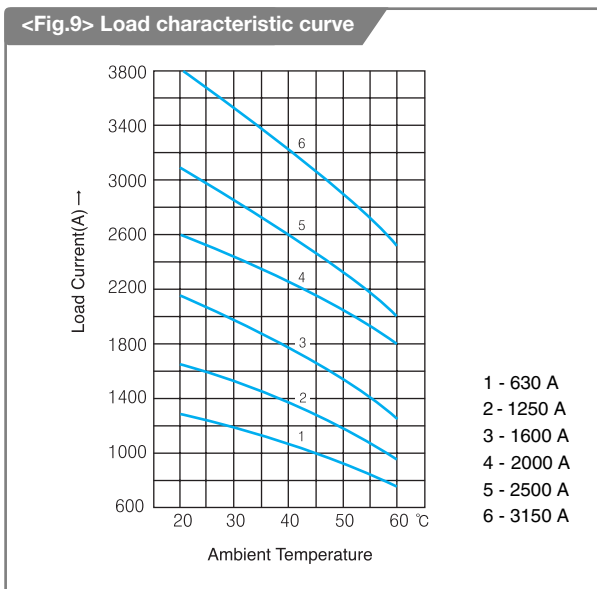

## Switching of Overload Transmission Lines and Cables

The relatively small capacitive currents of overhead transmission lines and cables at under no load condition can be safely interrupted without restrike and overvoltage development.

## Switching of Capacitors

HYUNDAI vacuum circuit breakers are the solution for capacitive applications by switching the circuit without restrike and over voltage. VCB above 7.2 kV 20 kA can switch ON/OFF up to 400 A capacitive load, and higher than 400 A circuit shall be informed in advance.

## Switching Unloaded Transformer

By the special contact materials, the chopping current of the vacuum circuit breakers is only 4 to 5 A, so overvoltage is limited when transformers disconnected at no load condition.

## Switching of Motors

Long electrical lifetime at rated current lets HYUNDAI vacuum circuit breakers be the excellent solution for high voltage motors.

Surge absorber is recommended on these motors, which have less insulation level or less than 600 A starting current. Even though low surge occurrence is the feature of HYUNDAI vacuum circuit breakers, the motor and the circuit itself can be protected efficiently by the surge absorber.

## Interruption of Transient Recovery Voltage

HYUNDAI vacuum circuit breakers can break the accident current properly at down stream of transformers, generators, and current limit chokes, whose rising rates of transient recovery voltage are higher than IEC Standard, even up to 10 kV/μs.

## Arc Quenching System

A metal-vapor arc discharge in the vacuum is initiated by the current to be interrupted as the contacts open. The current flows through this metal-vapor plasma until the next zero transition.

The arc extinguishes in the vicinity of the current zero, and the conductive metal-vapor condenses within a few microseconds on the metal surfaces.

As a result, the dielectric strength in the contact gap is rapidly rebuilt.

The rapid build-up of the dielectric strength at the contact gap enables the arc to be safely extinguished even if contact separation takes place shortly before a current zero transition. The maximum arcing time for the last pole to clear is therefore only up to 15 ms.

If the metal vapor arc discharge can be maintained within a certain level, the current is supposed to be chopped prior to current zero.

This chopping current must be controlled in order to prevent build-up of unduly high overvoltages when inductive circuits are switched. The sintered CrCu contact limits the chopping current up to 4-5 A.

The geometry and size of the contact are designed differently according to breaking current and interrupter type.

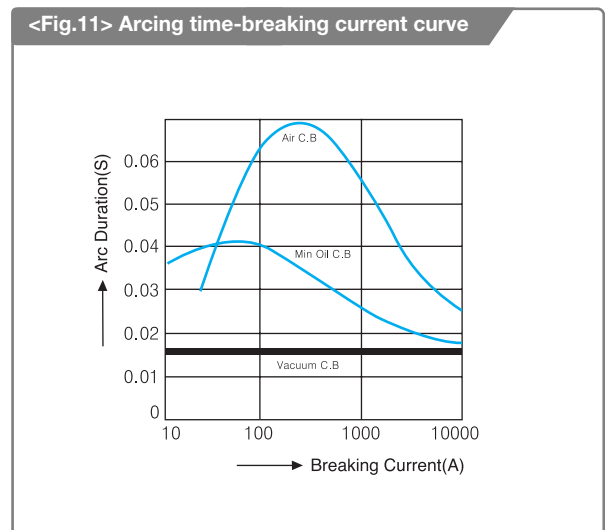
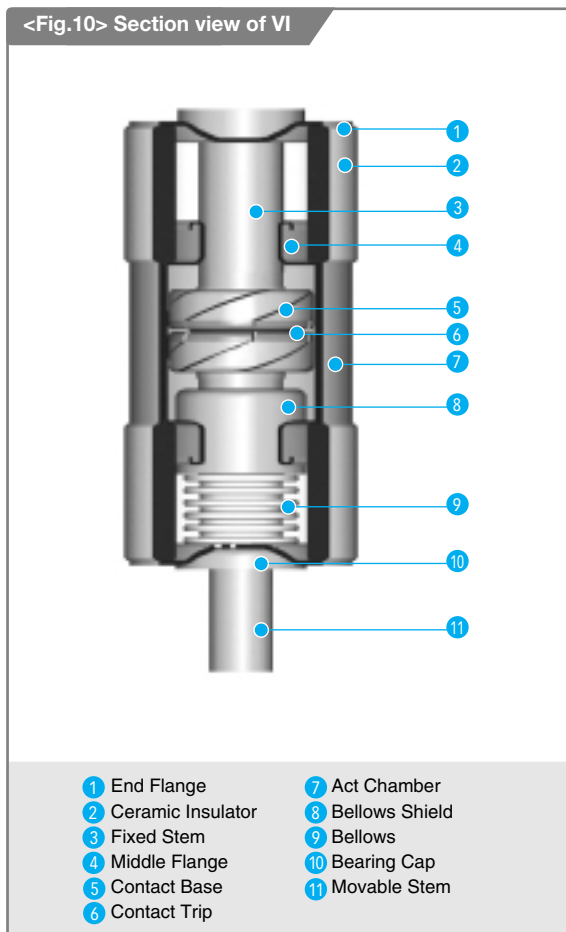

<Table 1> Arc Quenching Medium

Breaker Type	Arc Voltage (V)
Vacuum Circuit Breaker	20~200
SF <sub>6</sub> Gas Circuit Breaker	500~1000
Oil Circuit Breaker	1500~3000
Magnetic Blaster Circuit Breaker	1500~3000

# Service Life

## HVF / HVG Type

HYUNDAI vacuum circuit breaker needs minimum maintenance due to the simple operating mechanism and robust construction.

Vacuum circuit breaker shall be maintained periodically to ensure the perfect performance during mechanical and/or electrical lifetime.

Please refer to the instruction manual for the detailed information.

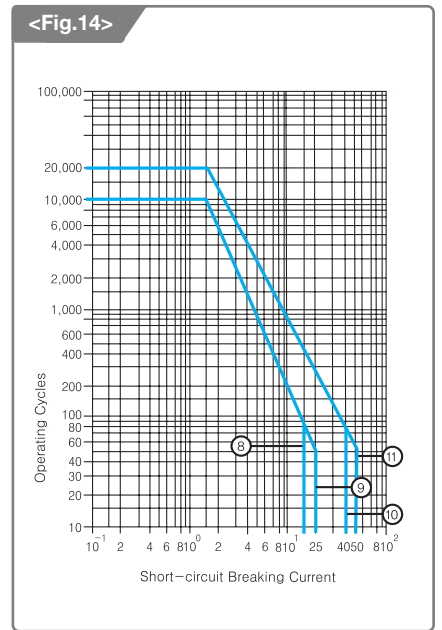
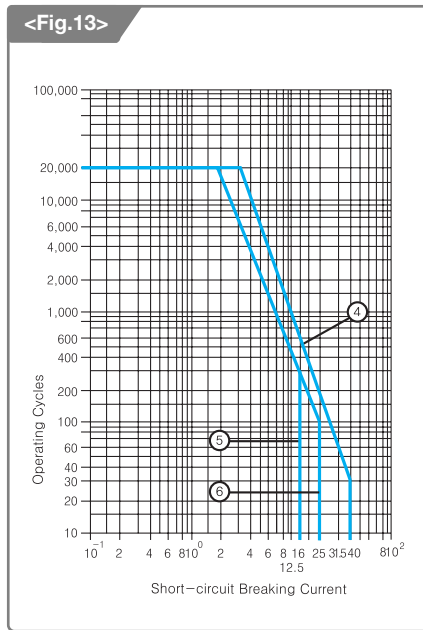
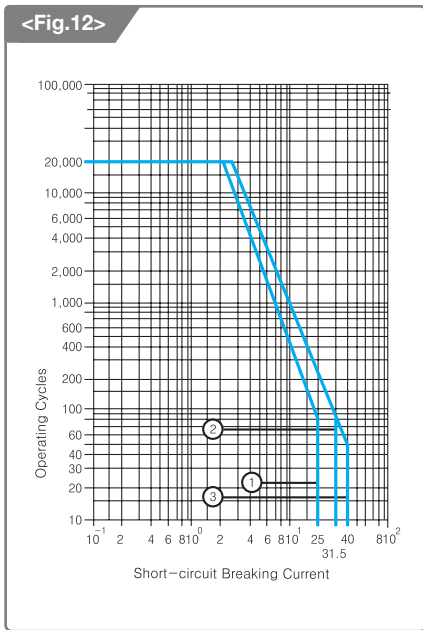

<Table 2> Electrical endurance curve number depending on VCB type

Model		HVF														HVG						
Rated Voltage	kV	7.2				12			15	17.5			24/25.8		36		38		7.2			
Rated Breaking Current	kA	4.76	25	31.5	40	25	31.5	40		25	31.5	40	12.5	25	25	31.5	40	8	12.5	20	25	
Curve Number	400 A																	8				
	630 A		1	2		1	2			1			5	6					8	9	9	
	1250 A	11	1	2	3	1	2	4	10	1	2	4	5	6	1	2	4			9	9	
	2000 A			2	3		2	4	10		2	4		6	1	2	4					
	2500 A				3			4				4			1							
	3150 A				3			4				4					2	4				

## Control & Auxiliary Circuits

### Charging Motor

HYUNDAI VCB adopts short-time duty charging motor, and the specification is stipulated on Table 3.  
Since the motor operating time is short, the maximum value and inrush current are disregarded.

### Auxiliary Contacts

The following versions are available:

X : Without control jack

C : Single control jack leaded out from the breaker body with a 0.8 m cable, 4NO+4NC

D : Double control jack leaded out from the breaker body with two 0.8 m cables, 10NO+10NC

Rating of auxiliary contacts

Operating voltage : Max. 250 V AC, DC

Continuous thermal current : 10 A

Making current : 30 A

Switching capacity : 2 A at DC 220 V, T=20 ms

### Solenoids

Closing solenoid and tripping solenoid operate latching mechanism for VCB springs, so the VCB can be controlled remotely.

The specification is mentioned on Table 3.

The solenoids unlatch the closing spring and opening spring to close and open the VCB, respectively.

<Table 3> Current consumption & operating voltage for motor and solenoids

Control Voltage	Control Current (A)						Voltage Range
	Motor		Closing Solenoid		Tripping Solenoid		
	HVF	HVG	HVF	HVG	HVF	HVG	
24 V DC	21	-	4.0	-	12.4	-	Motor : 85~110% Close : 85~110% Open : 85~110%
48 V DC	10.5	4.8	2.7	10.3	6.2	10.3	
60 V DC	8	3.8	1.7	8.4	5.0	8.4	
110 V DC	4.5	2.4	1.3	3.3	2.7	3.3	
125 V DC	4.5	2.8	1.5	3.5	2.4	3.5	
220 V DC	2.3	1.2	0.7	2.4	1.4	2.4	
110 V AC	6.4	3.6	1.3	3.3	2.7	3.3	
220 V AC	3.2	2.5	0.7	2.4	1.4	2.4	

## Standard Accessories

### HVF Type

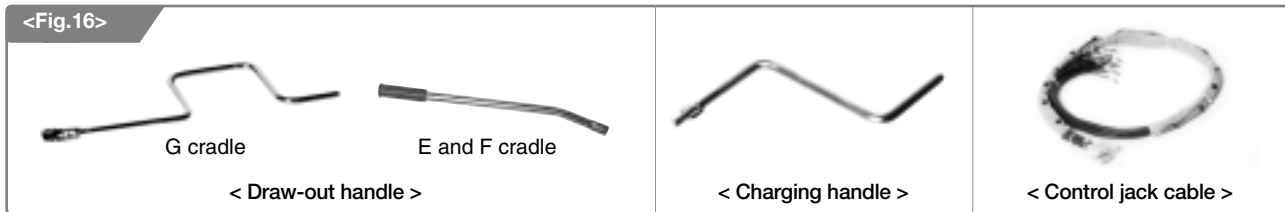

### HVG Type

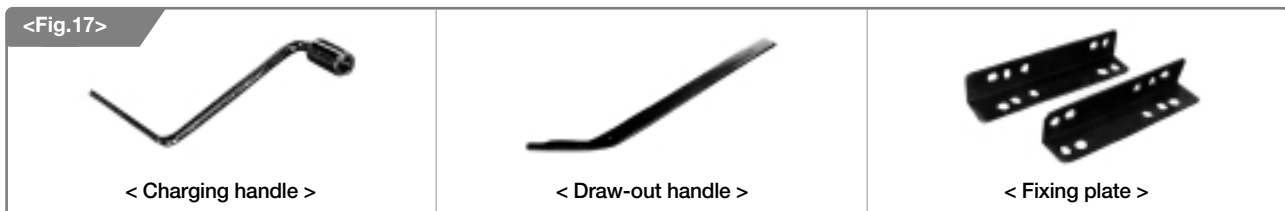

## Optional Accessories

### 2nd Shunt Release

2nd shunt releases are used to open the circuit breaker by appropriate protective relays, deliberate electrical or mechanical action. They are connected to control power (AC or DC); however, in special cases they may also be connected to voltage transformers.

### Undervoltage Release (UVR)

Undervoltage release (UVR) trips the VCB automatically when the control voltage drops to 35% of rated voltage. Then, the VCB can be closed when the control voltage recovers to 85%. UVR can be connected to voltage transformer, and can be applied to DC control power. Lockout relay is recommended along with UVR to block undesirable closing attempt.

### Lockout Relay

Lockout relay blocks VCB closing command when the control voltage is lower than 60% of rated voltage. VCB closing command can be carried out when the control voltage recovers to 85%. When lockout relay is installed, the VCB can be closed only when UVR is energized.

### Varistor Module

Varistor module protects charging motor and solenoids from the surge of DC control system. Potential damage caused by DC surge can be limited by applying varistor module to motor and solenoids.

### Condenser Trip Device (CTD)

Even though control power is lost, condenser trip device can trip the VCB of AC control system.

Order No.	HVFS-T7	HAFS-T9
Raged Input Voltage	AC 110 V	AC 220 V
Charging Voltage	DC 145V	DC 290V

### Vacuum Checker

Vacuum interrupter has longer lifetime than VCB, but vacuum degree can be check for more reliable operation.

Order No.	HAFS-VC9
Raged Input Voltage	AC 220 V
Raged Output Voltage	AC 11 kV / 22 kV
Dimension	W200 × L350 × H176

## Control Circuit

### HVF Type

#### Standard Circuit

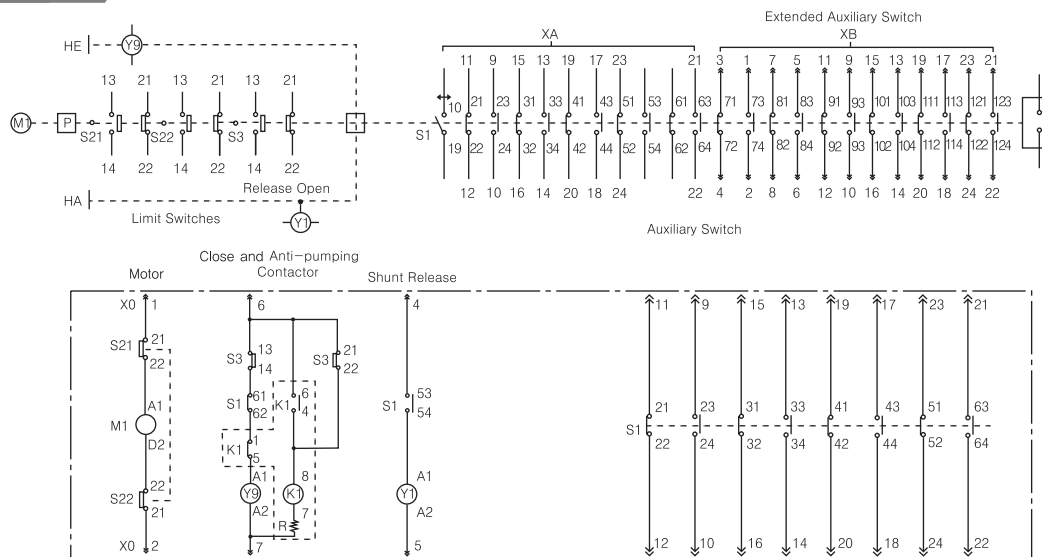

#### Optional Circuit

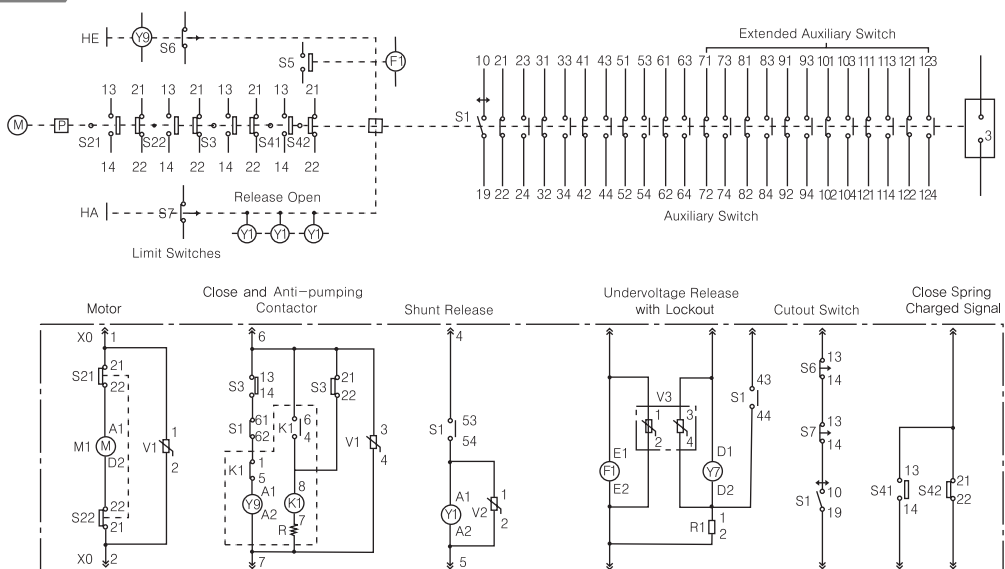

- F1 : Lockout Relay
- HA : Manual Tripping
- HE : Manual Closing
- K1 : Anti-pumping Relay
- M1 : Motor
- P : Stored Energy Mechanism
- Y1 : Tripping Solenoid
- Y7 : Under Voltage Release
- Y9 : Closing Solenoid
- R1 : Resistor
- S1 : Aux. Switch
- S3 : Limit Switch
- S41, S42 : Limit Switch (Spring Charged Signal)
- S6, S7 : Cutout Switch
- V1, V2, V3 : Varistor Module
- X0 : Plug / Socket

Diagram can be revised without notice.



**HVG Type**

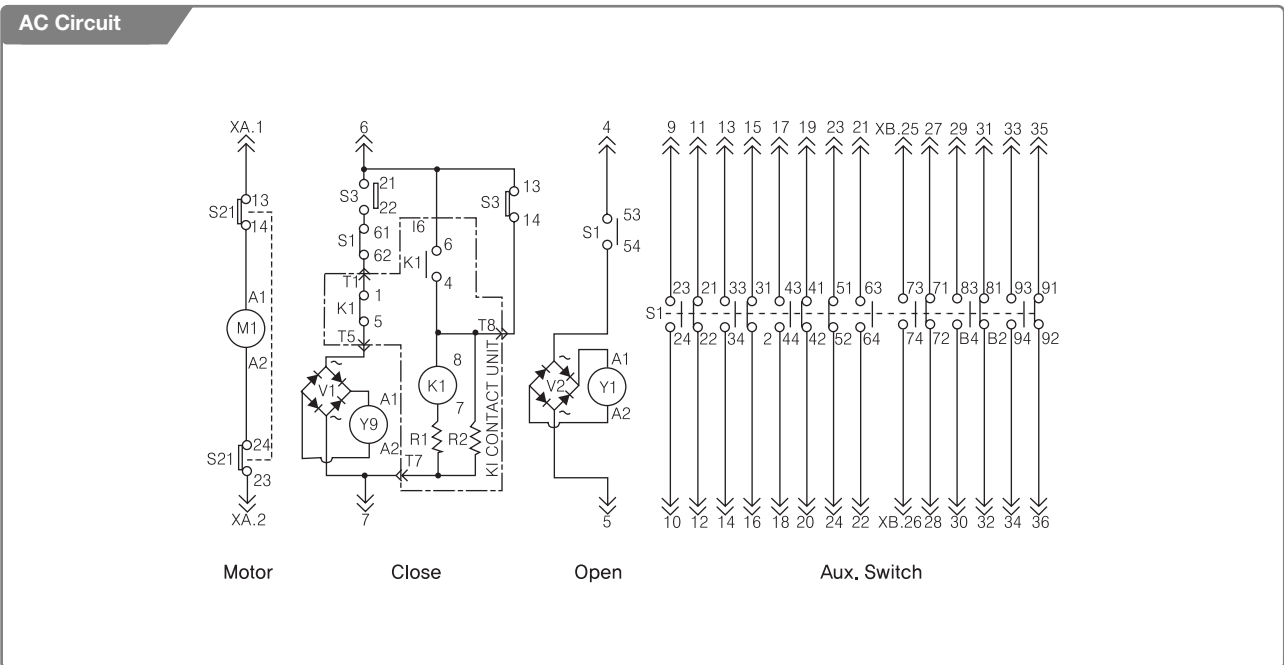
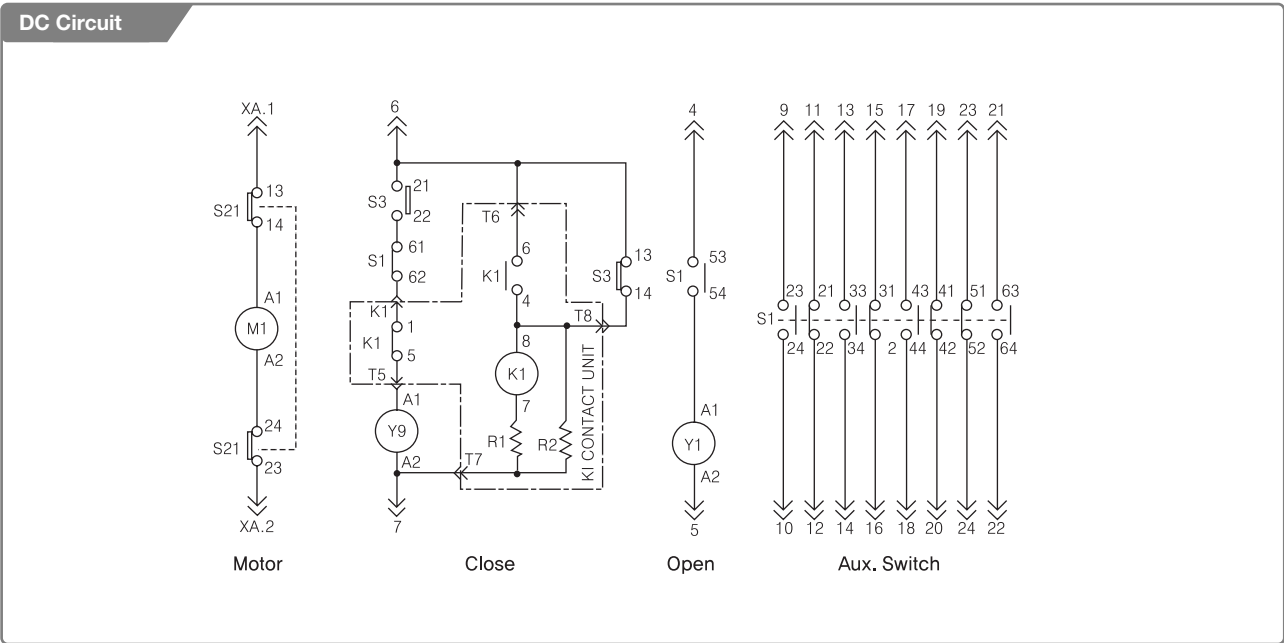

- K1 : Anti-pumping Relay
- M1 : Motor
- S3 : Limit Switch
- S21 : Limit Switch
- S1 : Auxiliary Switch
- V1 : Rectifier
- V2 : Rectifier
- R1, R2 : Resistor
- Y1 : Tripping Solenoid
- Y9 : Closing Solenoid
- XA : Plug/Socket
- XB : Plug/Socket

Diagram can be revised without notice.

Layout



HVF Type XA VCB

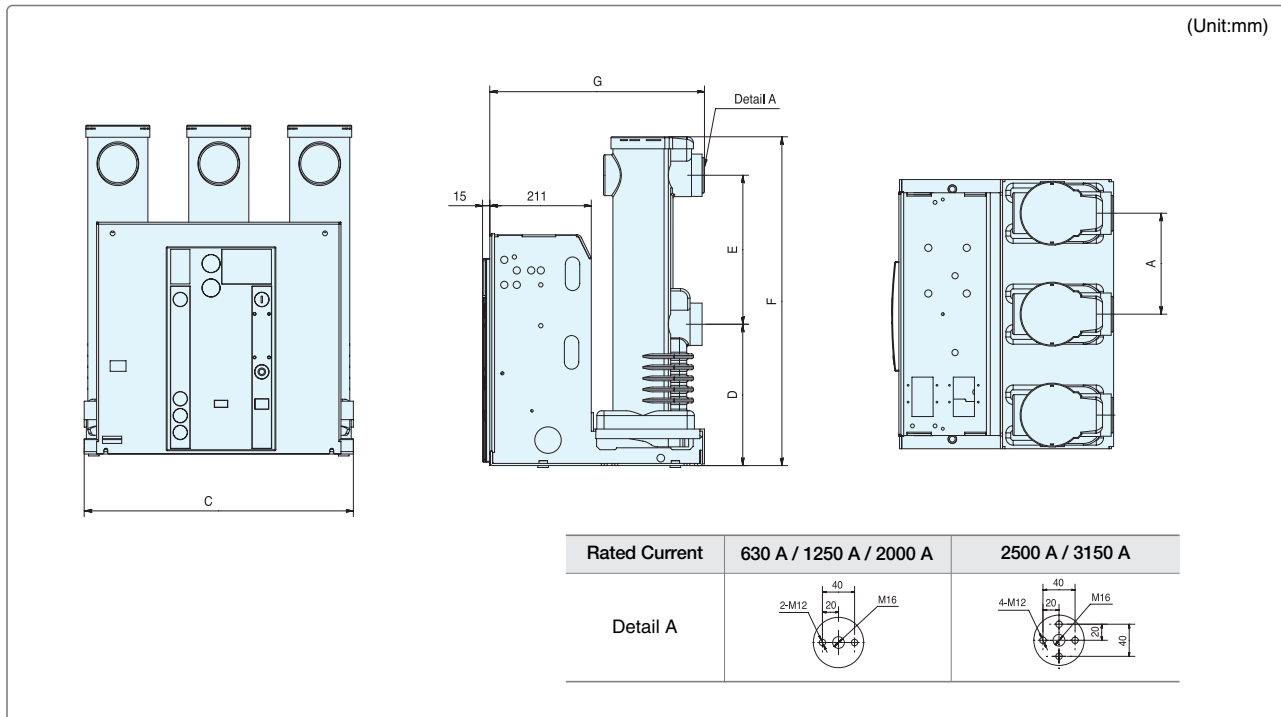

HVF Type ES/FS/GS VCB (Body)

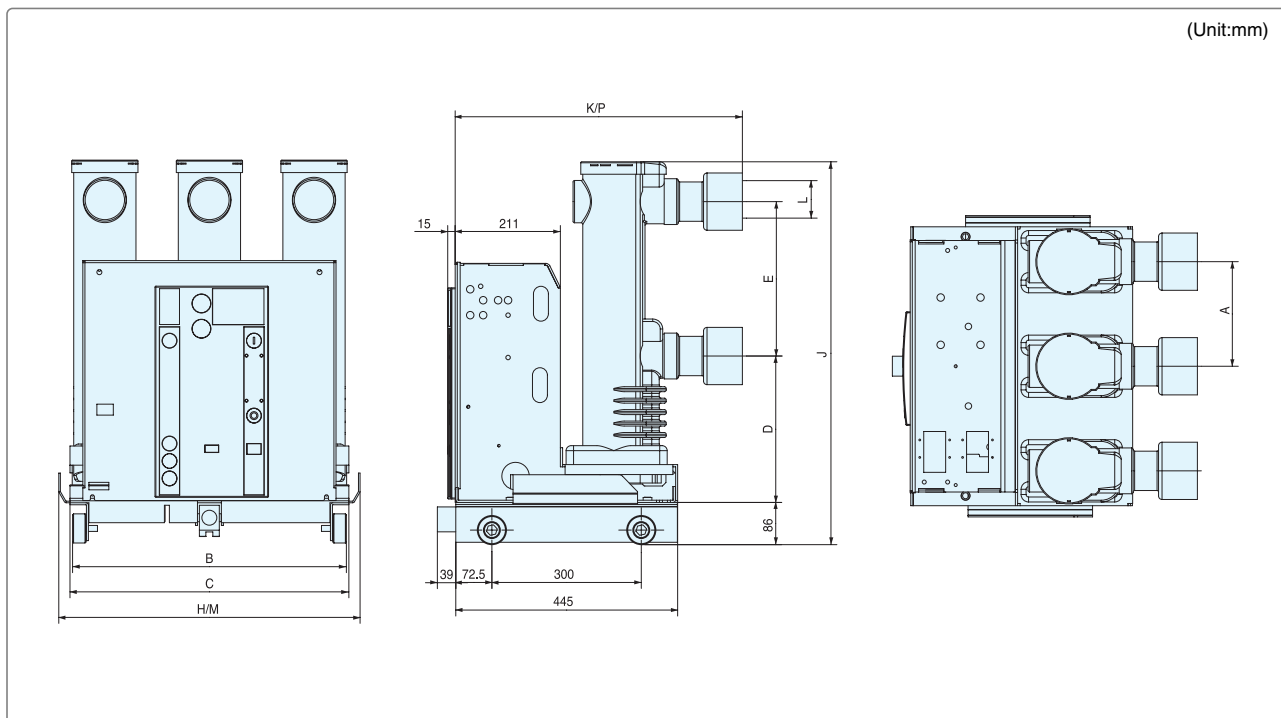

Draw can be revised without notice.

### HVF Type (XA/ES/FS/GS) VCB Dimension (Body)

(Unit:mm)

Type	XA/ES/FS/GS						ES/FS/GS	ES/FS				GS			
	A	C	D	E	F	G	J	B	L	H	K	B	L	M	P
HVF 1141	150	515	230	210	525	447	611	499	40	581	587	501	50	541	633
HVF 1142	150	515	230	210	525	447	611	499	50	581	587	501	50	541	633
HVF 1152	165	515	234	275	582	447	668	499	50	581	587	501	50	541	633
HVF 1154	165	515	234	275	582	447	668	499	60	581	587	501	60	541	633
HVF 1162	165	515	234	275	582	447	668	499	50	581	587	501	50	541	633
HVF 1164	165	515	234	275	582	447	668	499	60	581	587	501	60	541	633
HVF 1167	210	610	249	310	652	447	738	549	90	710	587	549	90	640	633
HVF 1372	165	535	234	254	645	447	-	-	-	-	-	-	-	-	-
HVF 2141	150	515	230	210	525	447	611	499	40	581	587	501	50	541	633
HVF 2142	150	515	230	210	525	447	611	499	50	581	587	501	50	541	633
HVF 2152	165	515	234	275	582	447	668	499	50	581	587	501	50	541	633
HVF 2154	165	515	234	275	582	447	668	499	60	581	587	501	60	541	633
HVF 2162	165	515	234	275	582	447	668	499	50	581	587	501	50	541	633
HVF 2164	165	515	234	275	582	447	668	499	60	581	587	501	60	541	633
HVF 2167	210	610	249	310	652	447	738	549	90	710	587	549	90	640	633
HVF 3141	150	510	230	210	525	447	610	499	40	581	587	501	50	541	673
HVF 3142	150	510	230	210	525	447	610	499	50	581	587	501	50	541	673
HVF 3152	165	515	234	275	582	447	668	499	50	581	587	501	50	541	673
HVF 3154	165	515	234	275	582	447	668	499	60	581	587	501	60	541	673
HVF 3162	165	515	234	275	582	447	668	499	50	581	587	501	50	541	673
HVF 3164	165	515	234	275	582	447	668	499	60	581	587	501	60	541	673
HVF 3167	210	610	249	310	652	447	738	549	90	710	587	549	90	640	673
HVF 3362	254	813	235	254	583	447	-	-	-	-	-	-	-	-	-
HVF 3364	254	813	235	254	583	447	-	-	-	-	-	-	-	-	-
HVF 6111	210	560	298	310	688	447	774	549	40	640	587	549	50	647	784
HVF 6112	210	560	298	310	688	447	774	549	50	640	587	549	50	647	784
HVF 6141	210	560	298	310	688	447	774	549	40	640	587	549	50	647	784
HVF 6142	210	560	298	310	688	447	774	549	50	640	587	549	50	647	784
HVF 6144	210	560	298	310	688	447	774	549	60	640	587	549	60	647	784

Dimension can be revised without notice.

# Layout

## HVF Type ES/FS VCB (Cradle)

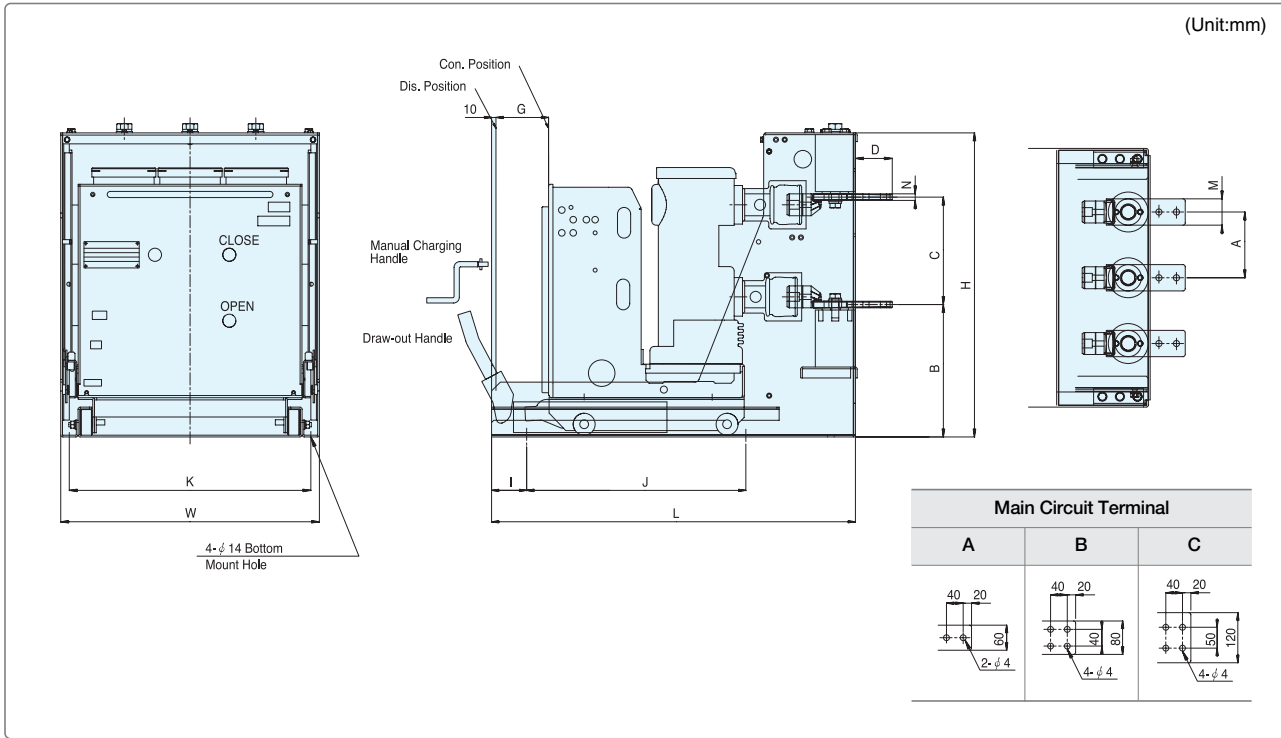

## HVF Type ES/FS VCB Dimensions (Cradle)

(Unit:mm)

Dimensions Type	ES/FS Cradle													
	W	H	L	A	B	C	D	G	I	J	K	M	N	Terminal
HVF 1141/2	590	693	830	150	302	245	84	120	80	500	550	60	15	A
HVF 1152/1	590	763	830	165	306	310	84	120	80	500	550	60	15	A
HVF 1154	620	763	830	165	306	310	84	120	80	500	550	80	20	B
HVF 1161/2	590	763	830	165	306	310	84	120	80	500	550	60	15	A
HVF 1164	620	763	830	165	306	310	84	120	80	500	550	80	20	B
HVF 1166/7	790	819	830	210	321	345	80	120	80	500	650	120	20	C
HVF 2141/2	650	693	910	220	302	245	84	200	80	600	600	60	15	A
HVF 2151/2	650	763	910	220	306	310	84	200	80	600	600	60	15	A
HVF 2154	650	763	910	220	306	310	84	200	80	600	600	80	20	B
HVF 2162	650	763	910	220	306	310	84	200	80	600	600	60	15	A
HVF 2164	650	763	910	220	306	310	84	200	80	600	600	80	20	B
HVF 2166/7	790	819	910	210	321	345	80	200	80	600	650	120	20	C
HVF 6111/2	920	972	940	280	370	345	84	230	100	670	650	60	15	A
HVF 6141/2	920	972	940	280	370	345	84	230	100	670	650	60	15	A
HVF 6144	920	972	910	300	370	345	84	230	100	670	650	80	20	B

Dimension can be revised without notice.



HVF Type GS VCB (Cradle)

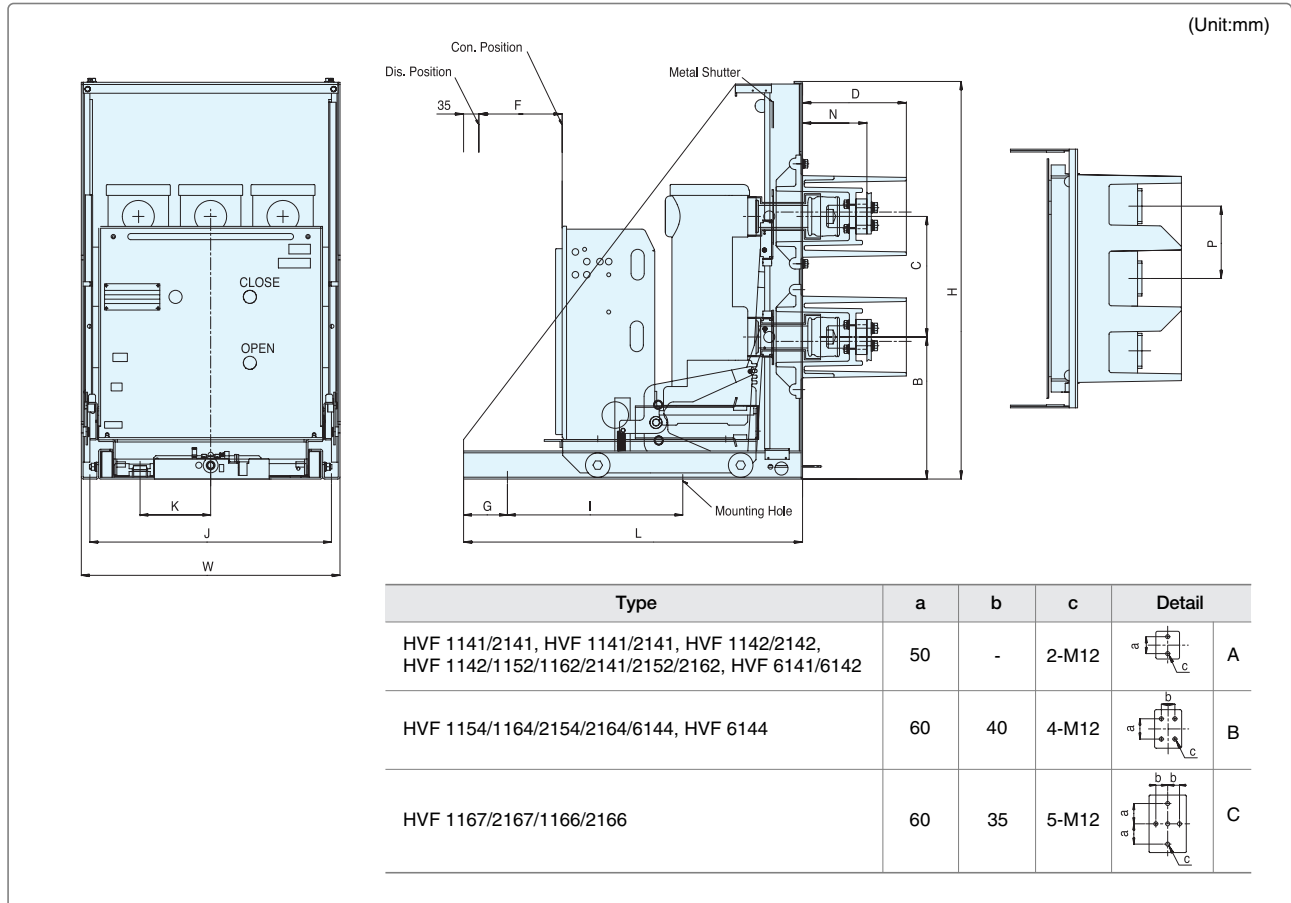

HVF Type GS VCB Dimensions (Cradle)

(Unit:mm)

Type	GS without Earthing Switch												
	P	W	H	L	B	C	D	F	G	I	J	K	N
HVF 1141/2	150	590	887	773	320	210	237	200	100	400	551	161	142
HVF 1152	165	590	887	773	324	275	237	200	100	400	551	161	147
HVF 1154	165	590	907	773	324	275	237	200	100	400	551	161	147
HVF 1162	165	590	887	773	324	275	237	200	100	400	551	161	147
HVF 1164	165	590	907	773	324	275	237	200	100	400	551	161	147
HVF 1166/7	210	690	1023	743	339	310	264	200	100	400	600	161	196
HVF 2141/2	150	630	887	773	320	210	237	200	100	400	551	161	142
HVF 2152	165	630	907	773	324	275	237	200	100	400	551	161	147
HVF 2154	165	630	907	773	324	275	237	200	100	400	551	161	147
HVF 2162	165	630	907	773	324	275	237	200	100	400	551	161	147
HVF 2164	165	630	907	773	324	275	237	200	100	400	551	161	147
HVF 2167	210	690	1023	743	339	310	264	200	100	400	600	161	192
HVF 6111/2	210	780	1060	896	388	310	371	300	150	600	650	161	292
HVF 6141/2	210	780	1060	896	388	310	371	300	150	600	650	161	292
HVF 6144	210	780	1060	896	388	310	371	300	150	600	650	161	292

Dimension can be revised without notice.

# Layout

## HVF Type CS VCB

(Unit:mm)

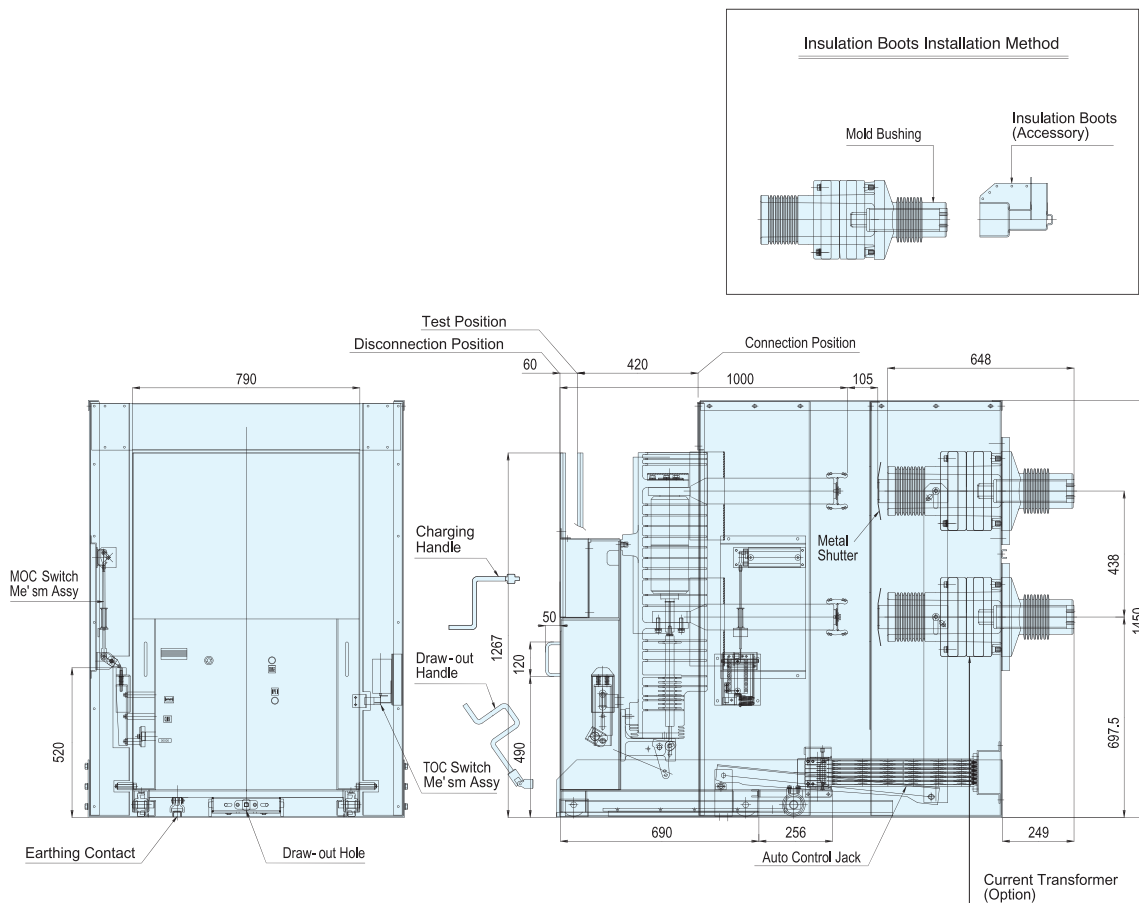

Type	Rating	Main Circuit Terminal
HVF 7052/7054/7057	38 kV 31.5 kA	
HVF 7062/7064/7067	38 kV 40 kA	

- CS Cradle : ANSI Standard. Metallic partition, bushing, auto jack, TOC, MOC & Shutter without cell.  
 - Dimension can be revised without notice.



HVF Type MS VCB

(Unit:mm)

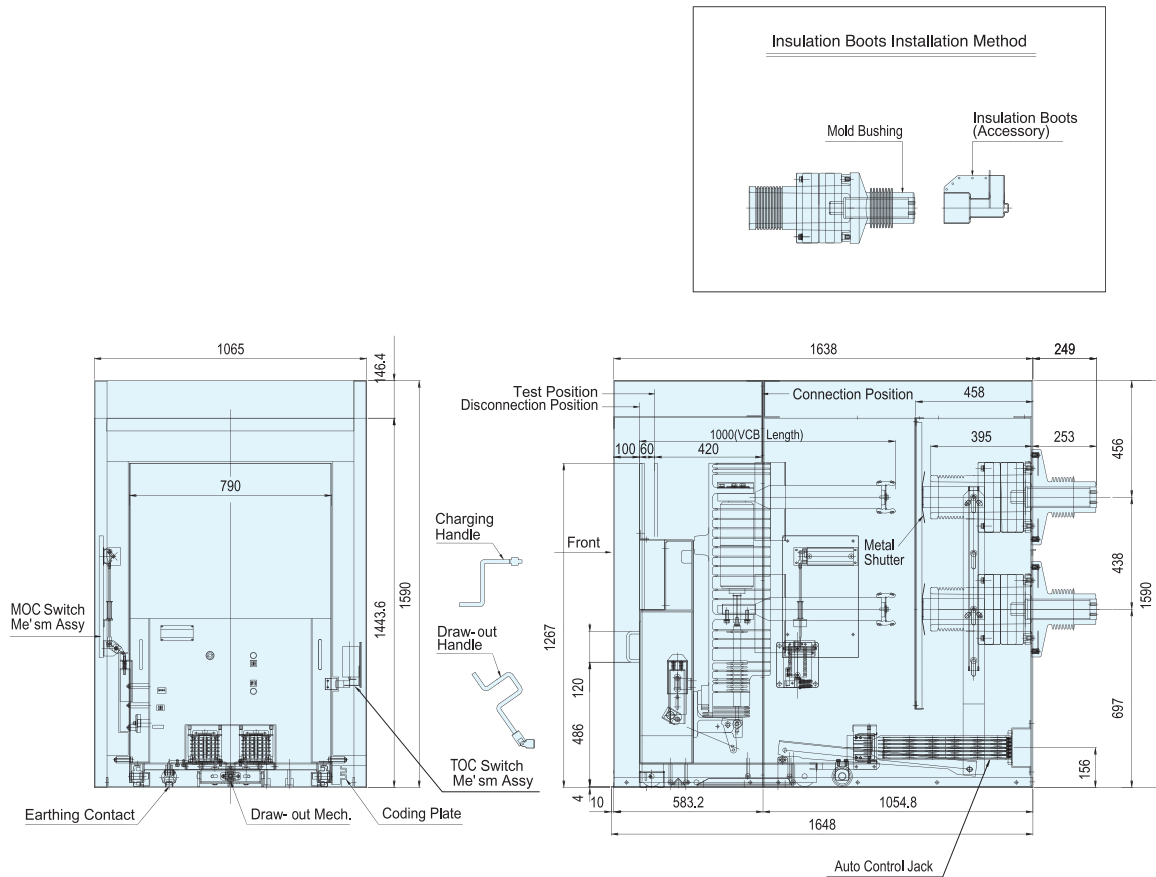

Type	Rating	Main Circuit Terminal
HVF 7052/7054/7057	38 kV 31.5 kA	
HVF 7062/7064/7067	38 kV 40 kA	

- MS Cradle : ANSI Standard. Metallic partition, bushing, auto jack, TOC, MOC & Shutter without cell.  
 - Dimension can be revised without notice.

# Layout

## HVF Type GS VCB

(Unit:mm)

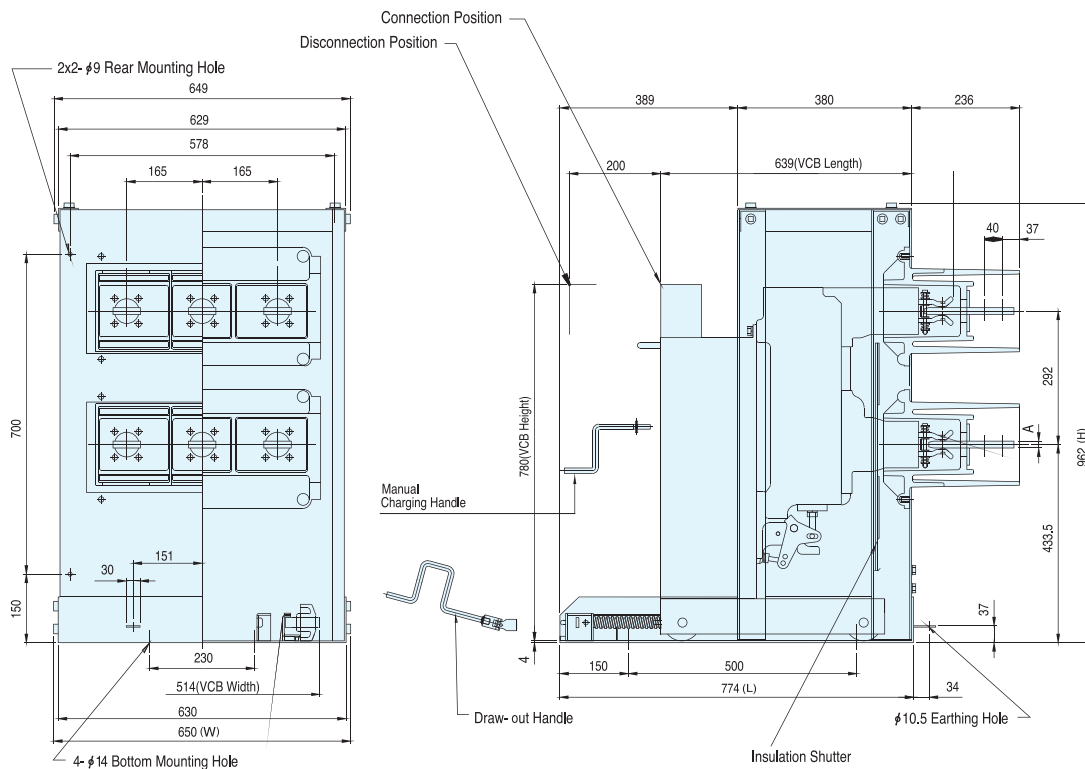

Type	Dimension (mm)				Terminal Type	Main Terminal	
	W	L	H	A		A type	B type
HVF 2041	650	774	962	10	A		
HVF 2042				15			
HVF 1051 / 1052				B			



# HVG

## HVG Type X VCB

(Unit:mm)

Type	A	B	C	D	E	F	G	H	I	J	K	L
HVG 1099	8 kA 400 A	443	61							130		
HVG 1011	12.5 kA 630 A	482	100	348	488	155	296	147	151	450	480	390
HVG 1131/2	20 kA 630 A / 20 kA 1250 A											
HVG 1141/2	25 kA 630 A / 25 kA 1250 A											

## HVG Type ES/FS VCB

(Unit:mm)

Type	A	D	E	F	G	H	I	J	K	L	M	N	O	ØP	
HVG 1099	8 kA 400 A	96					40								
HVG 1011	12.5 kA 630 A	136	70	130			500								
HVG 1131	20 kA 630 A			68	320		80	464	570	155	299	660	530	4-Ø14	
HVG 1132	20 kA 1250 A			140			540								
HVG 1141	25 kA 630 A														
HVG 1142	25 kA 1250 A														

Drawing can be revised without notice.

# Layout



## HVG Type GS VCB

(Unit:mm)

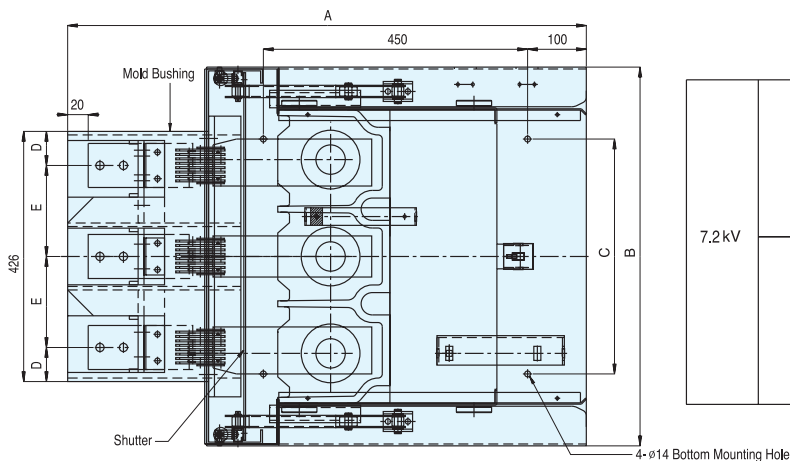

7.2 kV	8/12.5 kA	400 A	8	
		630 A	12	
	20/25 kA	630 A	10	
		1250 A	15	

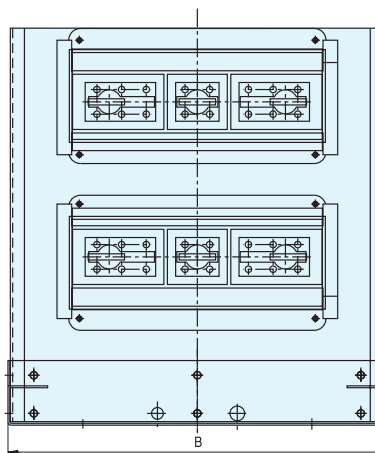
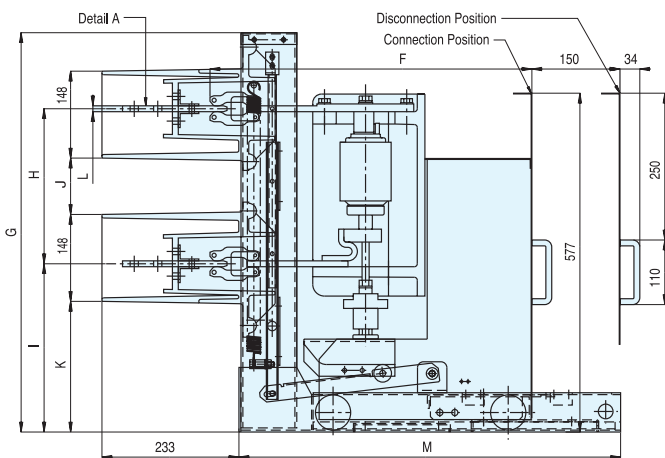

Type		A	B	C	D	E	F	G	H	I	J	K	L	M
HVG 1099	8 kA 400 A	874	540	320	83	130	525	660	220	294	52	230	8	640
HVG 1011	12.5 kA 630 A												12	
HVG 1131	20 kA 630 A		10											
HVG 1132	20 kA 1250 A		15											
HVG 1141	25 kA 630 A		10											
HVG 1142	25 kA 1250 A		15											

# Ordering Form

Please stipulate the complete ordering form as shown below. Special design, which is not identified, shall be informed in advance

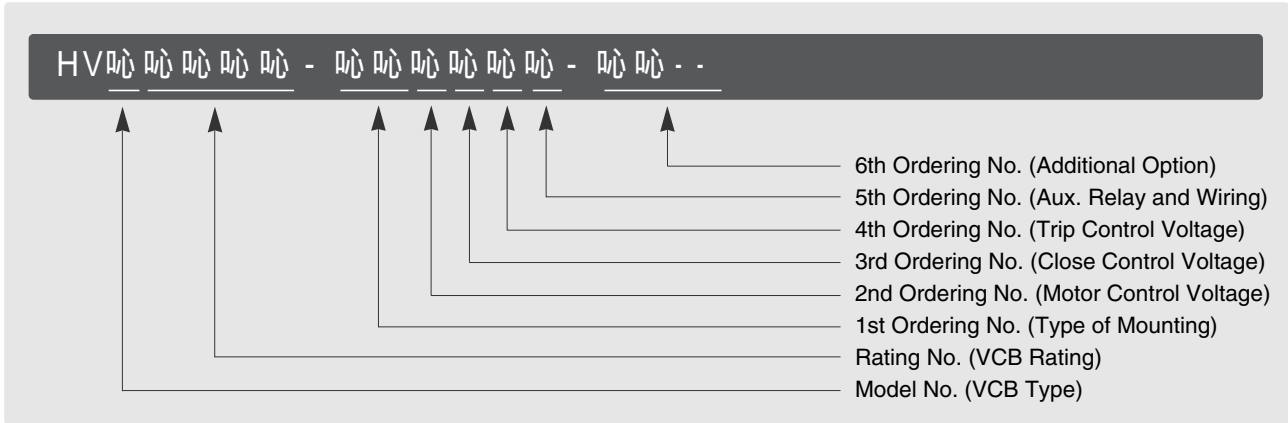

**1 VCB Type** HV - -

Type	Ordering No.	Type	Ordering No.
HVF type VCB	F	HVG type VCB	G

**2 VCB Rating No.** HV - -

Refer to the Type & Rating.

**3 1st Ordering No. | Type of Mounting |** HV - -

Ordering No.	Specification	Ordering No.	Specification
XA	Fixed type VCB	GS	With G cradle
ES	With E cradle	GE	With G cradle and earthing switch
FS	With F cradle		

HV - -

**4 2nd Ordering No. | Motor Control Voltage |** **5 3rd Ordering No. | Close Control Voltage |** **6 4th Ordering No. | Trip Control Voltage |**

Voltage	DC 24 V	DC 48 V	DC 60 V	DC 110 V	DC 125 V	DC 220 V	AC 110 V	AC 220 V
Ordering No.	1	2	3	4	5	6	7	9

**7 5th Ordering No. | Aux. Relay and Wiring |** HV - -

Ordering No.	Aux. Relay and Wiring
C	Single control jack leaded out from the breaker body with a 0.8 m cable, 4NO+4NC
D	Double control jack leaded out from the breaker body with two 0.8 m cables, 10NO+10NC
X	Without control jack

**8 6th Ordering No. | Additional Option |** HV - -

Order No.	Description	Type	Order No.	Description	Type
R	2nd Shunt Release( : Number of Voltage)	HVF	ZZ	Special Application	HVF/G
U	Under Voltage Release( : Number of Voltage)	HVF	EL	Electrical Local Closing	HVF
L	Lockout Relay( : Number of Voltage)	HVF	CO	Cut-out Switch	HVF
V	Varistor Module( : Quantities of Varistor)	HVF	CP	Closing Padlock Key	HVF
P0	Cam for Position Switch	HVF/G	S1	Spring Charged Signal(S41)	HVF
P2	Position Switch	HVF/G	DJ	Conventional Pluge Socket	HVF
KL	Position Padlock Key	HVF/G	EC	Earthing Switch(2 Position)	HVF
TP	Trip Padlock Key	HVF	E9	BIL 38/95 kV of 12 kV VCB	HVF
C	C.T Operated Release (1: 0.5 A, 2: 1.0 A)	HVF			

DC 24 DC 48V DC 60V DC 110V DC 125V DC 220V AC 110V AC 220V

[www.hyundai-elec.com](http://www.hyundai-elec.com)



<b>Head Office</b>	1 Jeonha-dong, Dong-gu, Ulsan, Korea Tel. 82-52-230-8101~8 Fax. 82-52-230-8100
<b>Seoul</b> (Sales & Marketing)	HYUNDAI B/D, 140-2, Gye-dong, Jongno-gu, Seoul, Korea Tel. 82-2-746-7510, 7589 Fax. 82-2-746-7648
<b>Orlando</b>	3452 Lake Lynda Drive, Suite 110, Orlando, Florida U.S.A. 32817 Tel. 1-407-249-7350 Fax. 1-407-275-4940
<b>London</b>	2nd Floor, The Triangle, 5-17 Hammersmith Grove London, W6 0LG, UK Tel. 44-20-8741-0501 Fax. 44-20-8741-5620
<b>Tokyo</b>	8th Fl., Yurakucho Denki Bldg. 1-7-1, Yuraku-cho, Chiyoda-gu, Tokyo, Japan 100-0006 Tel. 81-3-3212-2076, 3215-7159 Fax. 81-3-3211-2093
<b>Cairo</b>	Apartment No. 503, 5th Fl., Bldg. No. 7 Block 2, 9th Division, El-nasr Road, New Maadi, Cairo, Egypt Tel. 20-2-520-0148~9 Fax. 20-2-754-7528
<b>Sofia</b>	41, Rojen Blvd. 1271, Sofia Bulgaria Tel. 359-2-938-1068, 936-0300 Fax. 359-2-936-0742
<b>Yangzhong</b>	Lianzhong Avenue, Xinba Scientific and Technologic Zone, Yangzhong City, Jiangsu 212212, China Tel. 86-511-842-0666, 0500 Fax. 86-511-842-0668, 0231